

Model Answer

Important Instructions to examiners:

- 1) The answers should be examined by key words and not as word-to-word as given in the model answer scheme.
- 2) The model answer and the answer written by candidate may vary but the examiner may try to assess the understanding level of the candidate.
- 3) The language errors such as grammatical, spelling errors should not be given more Importance (Not applicable for subject English and Communication Skills).
- 4) While assessing figures, examiner may give credit for principal components indicated in the figure. The figures drawn by candidate and model answer may vary. The examiner may give credit for any equivalent figure drawn.
- 5) Credits may be given step wise for numerical problems. In some cases, the assumed constant values may vary and there may be some difference in the candidate's answers and model answer.
- 6) In case of some questions credit may be given by judgement on part of examiner of relevant answer based on candidate's understanding.
- 7) For programming language papers, credit may be given to any other program based on equivalent concept.

Q. No.	Sub Q.N.	Answer	Marking Scheme
Q.1		Attempt any <u>Five</u> of the following	20-Total Marks
1	a)	Draw a block diagram of 'Mechatronics System' and indicate the basic element on it.	4 M
	Ans:	<p>What is Mechatronics – general block diagram</p>	(Diagram:2 Marks, List of elements :any four 2 Marks)

OR

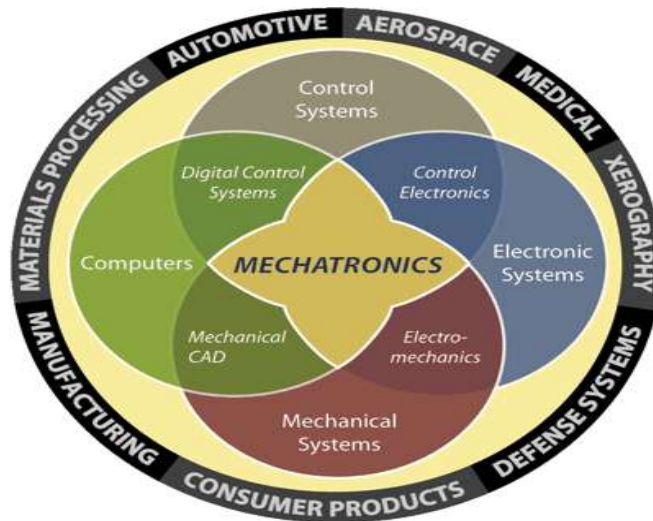

Element of Mechatronics System: (Any Other Element can be Consider)

A typical mechatronics system consist of mechanical system, electrical system and computer /information technology

Basic element of Mechatronics system are

Mechanical: Actuator, solenoids, motors, switch, sensor, transducer, gear, drive and so on

Electrical system/Electronics : Capacitor, semiconductor device, Amplifier, Filter, Digital and analog devices, accelerometer

Information Technology: Certain Software, System Engineering, Part programming, Artificial Intelligence, CAD, CAM

b) List velocity sensors and with diagram explain any one Type

4 M

Ans: Encoders, Tacho-generators Pyroelectric sensors, Moving coil type Velocity sensor

Explanation (ANY ONE)

Encoder

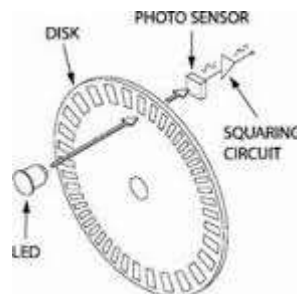

A digital optical encoder is a device that converts motion into a sequence of digital

(List:
1Mark,
Any one
explanation:
3 Mark)

pulses. By counting a single bit or by decoding a set of bits, the pulses can be converted to relative or absolute position measurements. Encoders have both linear and rotary configurations, but the most common type is rotary. Rotary encoders are manufactured in two basic forms: the absolute encoder where a unique digital word corresponds to each rotational position of the shaft, and the incremental encoder, which produces digital pulses as the shaft rotates, allowing measurement of relative position of shaft. Most rotary encoders are composed of a glass or plastic code disk with a photographically deposited radial pattern organized in tracks. As radial lines in each track interrupt the beam between a photoemitter-detector pair, digital pulses are produced.

Tacho-generator: Is used to measure angular velocity Can be of two types: variable reluctance or ac generator The variable reluctance one consist of toothed wheel of ferromagnetic material which is attached to the rotating shaft. As the wheel rotates, the air-gap between the coil and the Ferro-magnet changes. Thus the flux linked by the a pickup coil changes. This result in alternating emf in the coil. If the coil has n teeth and rotates with angular velocity w , then the flux and the induced voltage

Piezo electric sensors:

A piezoelectric sensor is device that uses the piezo electric effect to measure the changes in veliocity converting to electric quantity

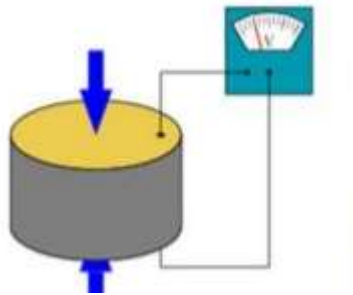

Moving COIL Type:

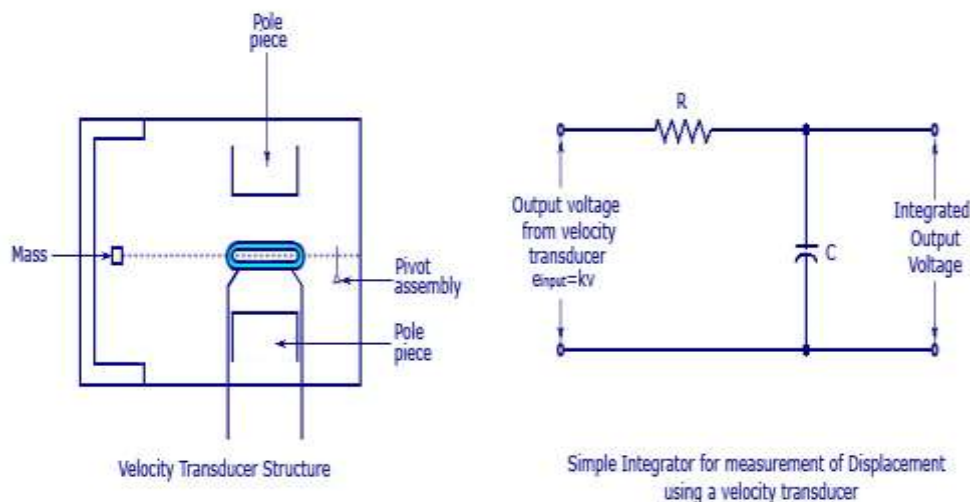

velocity transducer/sensor consists of a moving coil suspended in the magnetic field of a permanent magnet. The velocity is given as the input, which causes the movement of the

coil in the magnetic field. This causes an emf to be generated in the coil. This induced emf will be proportional to the input velocity and thus, is a measure of the velocity

c) **State four advantage of CNC system. What are G codes and M codes?**

4 M

Ans:

- Reduce the making/production cost
- Increases the productivity
- CNC improves the production planning control
- Low skill operator is required
- High accuracy and repeatability
- Simplification of flexible automation
- Greater flexibility
- Complex machining operations are also performed easily
- Indirect operating cost is reduced

(Advantage:
2 Mark
G code : 1
Mark
M code: 1
Mark)

G code: Address for preparatory commands:

G commands often tell the control what kind of motion is wanted (e.g., rapid positioning, linear feed, circular feed, fixed cycle) or what offset value to use.

M code: Miscellaneous function: Action code, auxiliary command; descriptions vary. Many M-codes call for machine functions, which is why people often say that the "M" stands for "machine", although it was not intended to.

d) **State the characteristics of 'Quick opening control valve'.**

4 M

Ans:

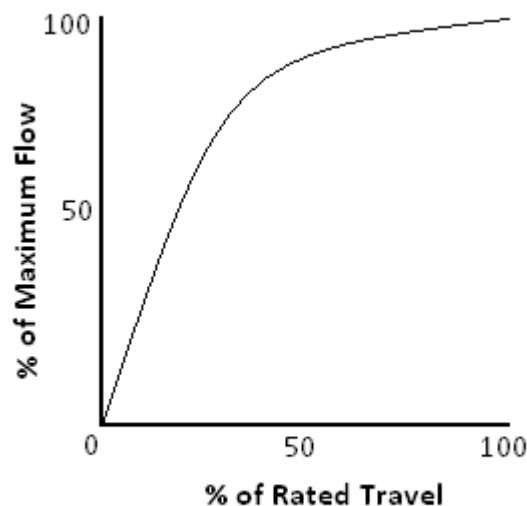

QUICK OPENING CHARACTERISTIC

(Diagram:2
Mark,
Statement:
2 Mark)

- Quick opening provides large changes in flow for very small changes in lift. It



	usually has too high a valve gain for use in modulating control. So it is limited to on-off service, such as sequential operation in either batch or semi-continuous processes.	
e)	State the function of manipulator and end effector.	4 M
Ans:	<p>Function of Manipulator: Arm and Body - The arm and body of a robot are used to move and position parts or tools within a work envelope. They are formed from three joints connected by large links. Wrist - The wrist is used to orient the parts or tools at the work location. It consists of two or three compact joints.</p> <p>Functions Of an End Effector : 1. End effector is the device at the end of a robotic arm designed to interact with the environment. 2. End effectors originates from robotic manipulators (robotic arm) It is the last link of the robot. 3. It is a last link of the robot. It is similar to human hand with or without finger. It incorporates various sensors</p>	(Manipulator: 2 Mark and End effector: 2 Mark)
f)	Define the term 'MEMS'. List down the various engineering application of MEMS.	4M
Ans:	<p>Definition: Micro-electromechanical systems (MEMS) is a technology that combines computers with tiny mechanical devices such as sensors, valves, gears, mirrors, and actuators embedded in semiconductor chips.</p> <p>Application Of MEMS:</p> <ol style="list-style-type: none"> 1. Adaptive Optics for Ophthalmic Applications 2. Optical Cross Connects 3. Air Bag Accelerometers 4. Pressure Sensors 5. Mirror Arrays for Televisions and Displays 6. High Performance Steerable Micro mirrors 7. RF MEMS Devices 8. Disposable Medical Devices 9. High Force, High Displacement Electrostatic Actuators 10. MEMS Devices for Secure Communications 	(Definition :1 Mark Application: 3 Mark) [Note: Marks May be given relevant to additional application]
g)	Enlist the various mechanical actuating system and explain any one in brief.	4M
Ans:	<ol style="list-style-type: none"> 1. Force amplification e.g. levers 2. Change of speed e.g. gears 3. Transfer of rotation about one axis to rotation about another axis e.g. belt 4. Particular types of motion e.g. that given by a quick return mechanism 5. The four bar chain and the slider –crank chain 6. CAM 7. Ratchet & Pawl <p>Explanation: Gear:</p>	(List :2 Mark Explanation : 2 Mark) [Diagram Optional]



	<p>Rotary motion can be transferred from one shaft to another by a pair of rolling cylinders. The transfer of the motion between the two cylinders depends on the frictional forces between the two surfaces in contact. Slip can be prevented by the addition of meshing teeth to the two cylinders. Also gears can be used to transfer rotating motion for shafts which have axis inclined to one another, i.e. the two shafts intersect (bevel gears).</p> <p>Belt-Chain: Is essentially a pair of rolling cylinders with the motion of one cylinder being transferred to the other by a belt. The transmitted torque is due to differences in tension that occur in the belt during operation. This difference results in a tight side and slack side for the belt.</p> <p>Ratchet & Pawl: It consists of a wheel, called a ratchet, with saw-shaped teeth which engage with an arm called Pawl. The arm is pivoted and can move back and forth to engage the wheel. The shape of the teeth is such that rotation can occur in only one direction. (used in winch to wind up a cable on drum)</p> <p>CAM: A cam is a body which rotates or oscillate and in doing so, imparts a reciprocating or oscillatory motion to a second body called the follower, with which it is in contact. CAMS As the cam rotates so the follower is made to rise, dwell and fall; the length of times spent at each of these positions depends on the shape of the cam. The rise section: is the one that drives the follower upwards, The fall section: is the one that lowers the follower. The dwell section is the one that allows the follower to remain at the same level for a significant period of time. It is circular with a radius that does not change.</p>	
Q 2	Attempt any Four of the following:	16 M
	<p>a) What is 'Mechatronics'? State its importance in engineering with suitable examples.</p> <p>Ans: Mechatronics: Mechatronics is the synergistic integration of mechanical engineering with electronics and intelligent computer control in designing, manufacturing processes and production. It helps to develop atomized, reliable and efficient manufacturing/production systems to produce high quality products.</p> <p>Importance of Mechatronics in various engineering fields:</p>	<p>4 M</p> <p>(Mechatronics: 2Marks, Importance any 2: 2 Marks)</p>

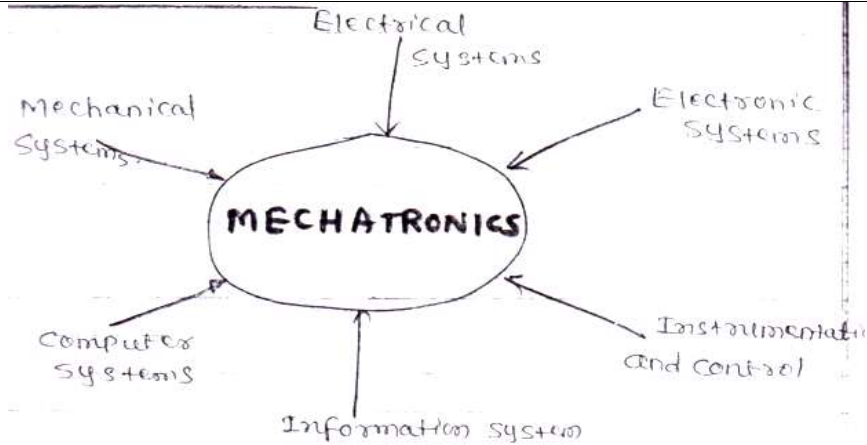

Mechanical System: These system deal with behavior of matter under the action of forces. Mechanical system like hydraulic, pneumatic, rotational or translational, thermal, Fluid etc. are used in mechatronic applications. These systems are interfaced with computer through sensors, actuators and electronic systems.

Electrical systems: Electrical components mostly used are electrical motors (ac and dc) generators, relays, circuit breakers, switches and so forth.

Electronic systems: Analog electronics involves action and passive components such as resistor, capacitor, inductor, diodes and transistors digital circuits contain logic, gates, counters, Flip-flops, memories, microcontroller and process.

Instrumentation & control system: It includes transducer, signal conditioning, output device such as analog meters, display devices recorders and printers.

Information system: It related with all the aspects regarding information transmission from signal processing to control system and analysis techniques. It is a combinational of communication systems, signal processing, control systems and numerical methods.

Computer system: It is combinational of hardware and software. In mechatronic applications hardware is computer-specific circuit like flip-flops, counters registers, memories software is nothing but system & application.

b) State the Function of ‘signal Conditioner’ in measurement system.

4 M

Ans: In mechatronic systems, processing and controlling of physical parameters like temperature, pressure, flow, etc. is carried out by converting them into electrical signals by means of suitable transducers. Depending upon the excitation system or requirement of power supply, transducers are classified as passive and active. The excitation source (ac or dc) is necessary for passive transducers like potentiometers, strain gauges, etc. because these transducers do not produce their own output voltage or current. Similarly, amplification stage is also necessary to increase the level of output signal. Active transducers (piezoelectric, thermocouple, etc.) produce their own electrical output when physical quantities are applied to them, but amplifier stage is used to bring the output signal up to a suitable level. In both cases, amplifiers are used because the output is at low level. The output signal is amplified to bring it compatible with control elements, indicating and display devices, recorders, controllers and so on.
Figure shows block diagram of an electronic measurement system.

**Diagram:1
M & State
Function:3
M**

Block diagram of an electronic measurement system.

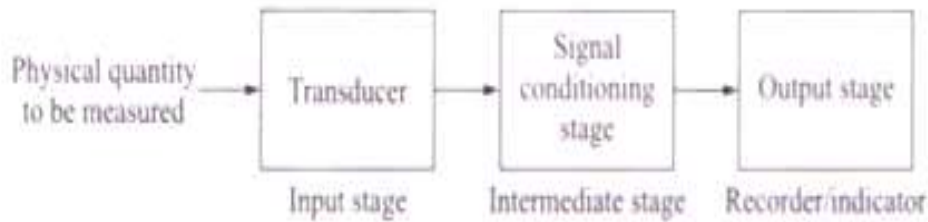

The input stage here is transducer and output stage is recording or display device or control element. These two stages are interfaced by intermediate stage, which is signal conditioning stage. Signal conditioning elements are necessary for performing linear operations like amplification, attenuation, integration and addition. These devices also perform non-linear operations like clipping, clamping, modulation, demodulation, filtration and so on. Other devices are analog-to-digital or digital-to-analog converters, sample and hold amplifier and so on.

Some transducers like strain gauges need bridge amplifiers for calibration that are also signal conditioning elements. The excitation source used may be ac or dc voltage signal. There are two types of signal conditioning systems depending upon the excitation source used, that is ac and dc.

c) **Explain how a PLC can be used to handle an analog input.**

4 M

Ans: For analog operation, the level of a PLC input signal is sensed by an analog input module, like in a data acquisition system when input parameters may be the analog values of temperature or pressure. Similarly, the output may be an electrical signal controlling the current through a system which can operate positions between ON and OFF.

Analog PLC systems are of two general types: the BCD and the straight numerical. The BCD is called multi-bit type. The inputs include data from devices like thumbwheels, encoders. BCD codes are fed into the PLC input module from the thumbwheel output. Other possible BCD-type inputs are barcode readers and encoders. Similarly, the output may be a digital display, various position actuators and solenoid motors.

A straight numerical type of module is used for a large variety of input devices like a potentiometer inputs a linear varying electrical value. Other inputs are thermocouples, strain gauges and signal generators which generate electrical signals.

The method in which these analog inputs are handled is of course similar to a microprocessor. First the data is to be converted into digital signals and then processed by the PLC. On the output side, the output data from the PLC are converted into analog data and given to the output device. Figure shows block diagram of this process.

Initially the data handled is in BCD, and then as soon as it reaches the PLC, it is first converted into machine code and then the necessary control signals are generated to the output module.

**Diagram:1
M &
Explanation
:3M**

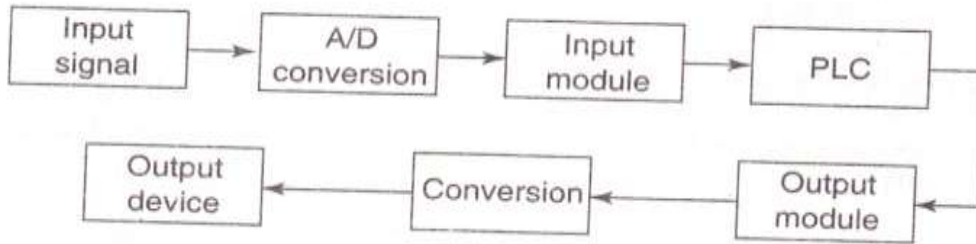

d) State the working principle of 'Solenoid valve' with neat sketch.

4 M

Ans: **Working Principle:**

A solenoid is a simple electromagnetic device that converts electrical energy directly into linear mechanical motion, but it has a very short stroke (length of movement), which limits its applications. A solenoid valve is the combination of a basic solenoid and mechanical valve. So a solenoid valve has two parts namely- Electrical solenoid, mechanical valve. Solenoid converts electrical energy to mechanical energy and this energy is used to operate a mechanical valve that is to open, close or to adjust in a position.

Diagram:

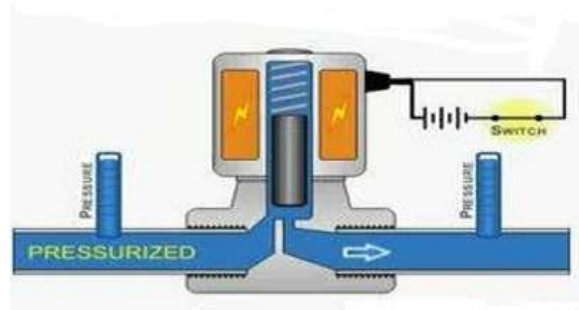
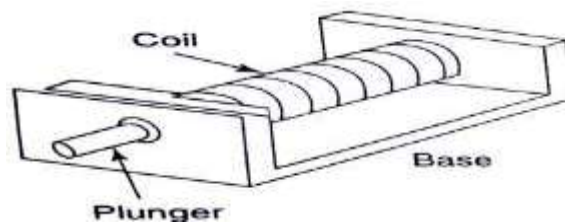
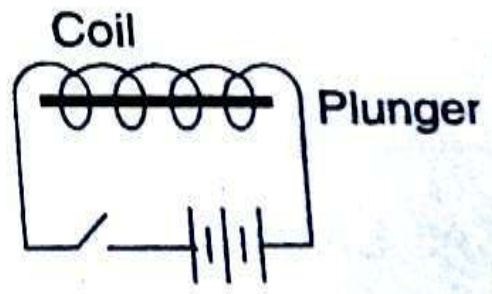

Fig. solenoid valve
OR



OR



[Working Principle: 2 Mark
,Diagram (any 1): 2Mark]

[Note: students can any other correct Diagram]

OR

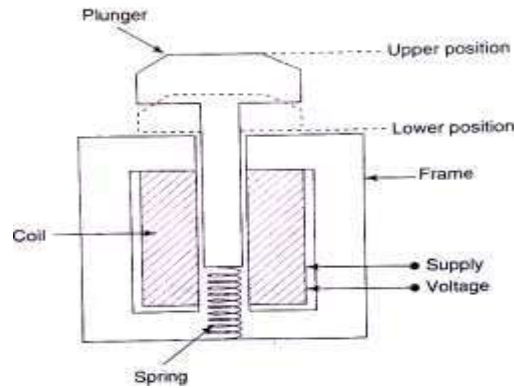

e) Explain the basic element of Robotic system with Block diagram.

4M

Ans: Block Diagram:

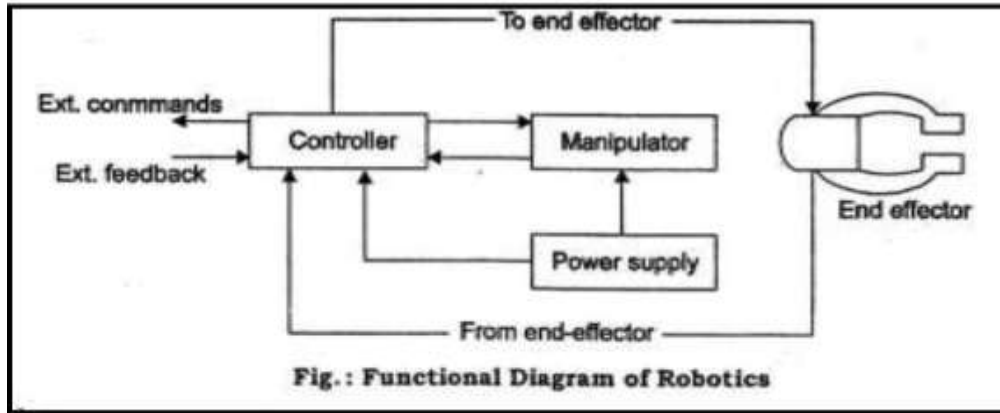

[Diagram- 2 Marks, Explanation -2 Marks)

OR

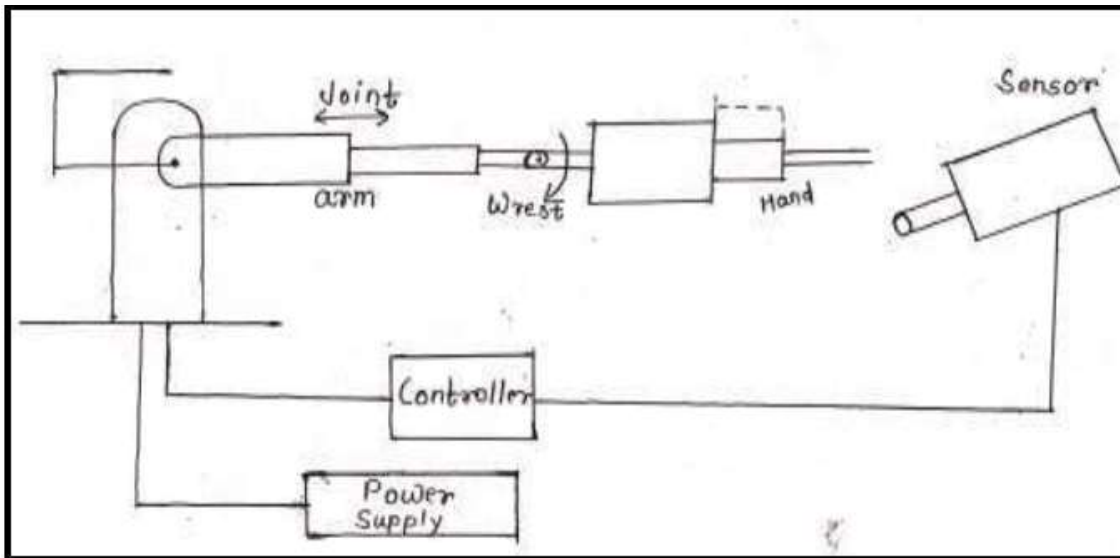

Fig. Block diagram of robot system

OR

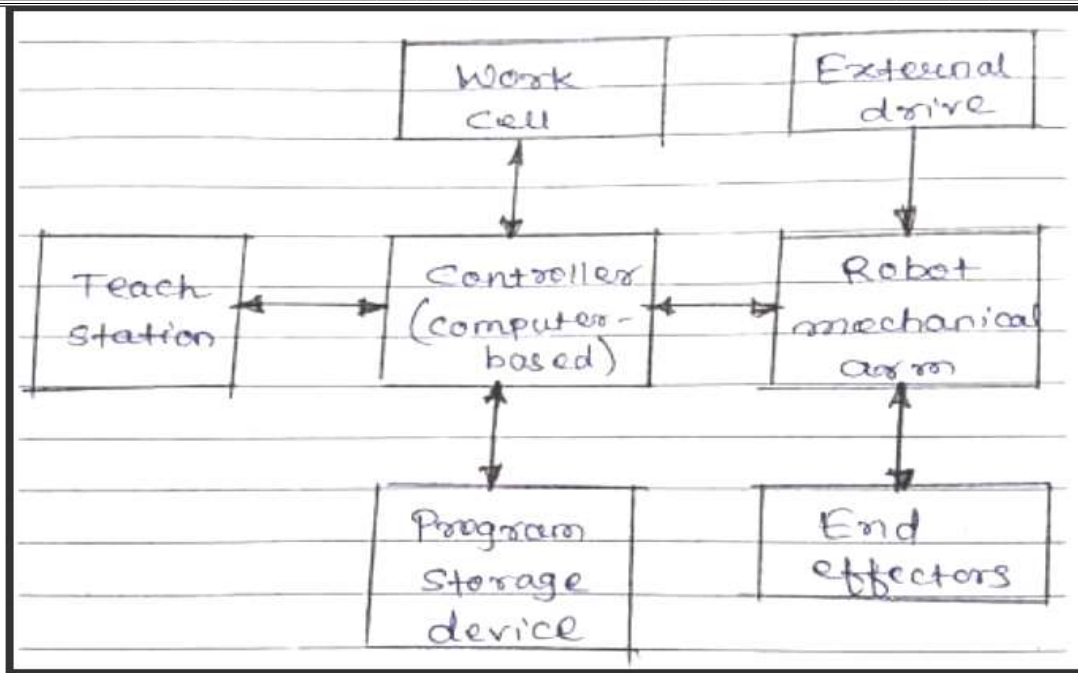

Fig. block diagram of robot system

Components of Robots:

A robot is a complex machine which may contain mechanical, electrical, pneumatic, hydraulic and microelectronic components. Essentially a robot consists of four elements.

- (1) Drive system: The drive system controls and velocity of end effectors. There are three major type of drive used in robots, namely,
 - Electrical drives;
 - Hydraulic drives;
 - Pneumatic drives.
- (2) Control system: The control system controls and velocity of the end effectors of the robot based on the logical sequence and operating programs.
- (3) Measuring system: A measurement of output is important; the control system continuously measures the actual position during a motion cycle and compares it with the theoretical values required, in order to provide a correction action.
- (4) Sensors: the main function of to permit the robot to interact with the environment in an intelligent manner. Various types of sensors are available nowadays including tactile, proximity, ultrasonic ranging and vision sensors.

f)	Describe the working of PLC based automatic car park barrier system with block diagram.	4 M
Ans:	(Ladder diagram can be optional) Automatic car parking system allow to park maximum numbers of car in parking zone according to size of parking zone.	[Diagram- 2 Marks, Explanation -2 Marks)

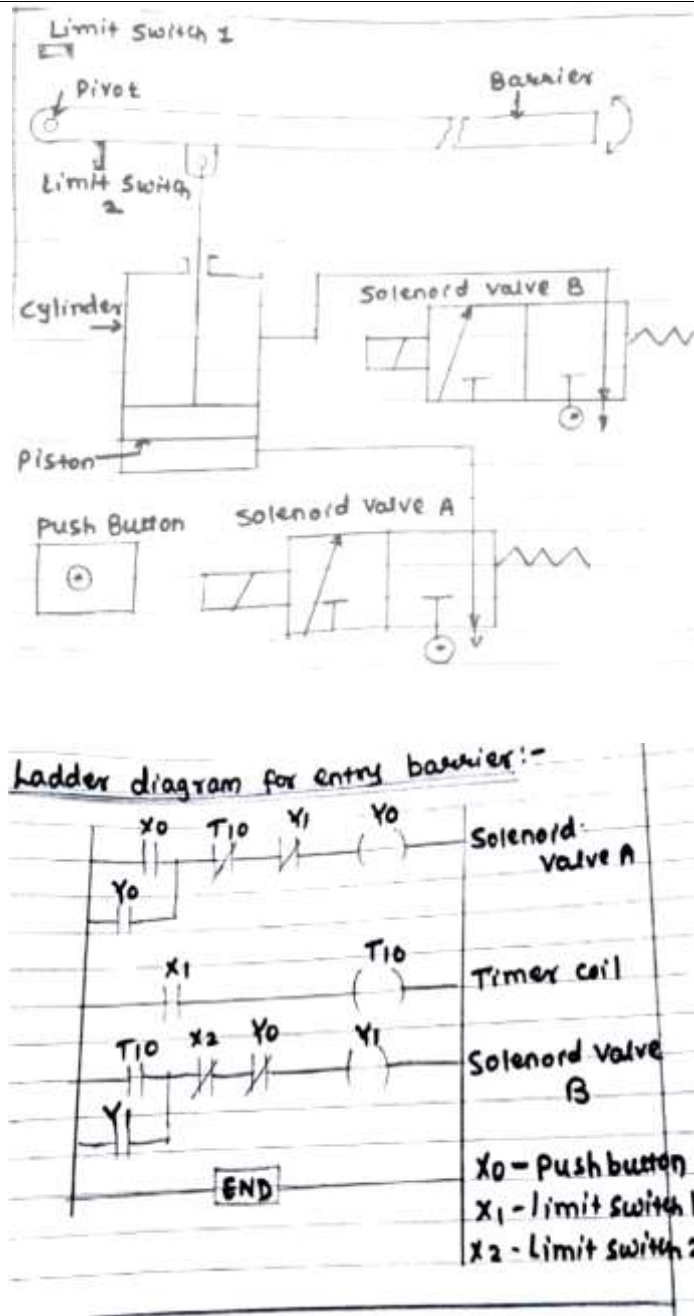

In parking zone number of vehicle parked in parking zone is less than available parking space then automated parking system allow entering next car in parking zone.
In parking zone number of vehicle parked in parking zone is equal to available parking space then automated parking system does not allow enter next car in parking zone.

Q. 3 **Attemot any FOUR of the following:** **16 M**

a) **Explain the function of PLC. Draw a block diagram of basic PLC configuration.** **4 M**

<p>Ans:</p>	<div data-bbox="370 172 1193 682" data-label="Diagram"> </div> <p>programmable logic controller (PLC), or programmable controller is an industrial digital computer which has been ruggedised and adapted for the control of manufacturing processes, such as assembly lines, or robotic devices, or any activity that requires high reliability control and ease of programming and process fault diagnosis.</p> <ol style="list-style-type: none"> 1. The functionality of the PLC has evolved over the years to include sequential relay control, motion control, process control, distributed control systems, and networking. 2. The data handling, storage, processing power, and communication capabilities of some modern PLCs are approximately equivalent to desktop computers. 3 PLC-like programming combined with remote I/O hardware, allow a general-purpose desktop computer to overlap some PLCs in certain applications. Desktop computer controllers have not been generally accepted in heavy industry because the desktop computers run on less stable operating systems than do PLCs, and because the desktop computer hardware is typically not designed to the same levels of tolerance to temperature, humidity, vibration, and longevity as the processors used in PLCs 	<p>(Diagram:2 Mark Function:2 Mark)</p>
<p>b) Ans:</p>	<p>State and explain working principle of 'Hall effect sensor' with sketch.</p> <div data-bbox="535 1396 1039 1680" data-label="Diagram"> </div> <ul style="list-style-type: none"> • When a beam of charged particles passes through a magnetic field. The beam deflected from its straight line path due to the forces acting on the particles. • A current flowing in a conductor, such as a beam of moving charges and thus can be deflected by a magnetic field is called “ Hall Effect” <p>The working principle of a Hall Effect sensor is that if a strip of conducting materials carries a current in the presence of a transverse magnetic field.</p> <ul style="list-style-type: none"> • The different of potential is produced between the opposite edges of the conductor. 	<p>4 M (Statement :1Mark; Diagram and Explanation : 3 M)</p>

- The magnetic of the voltage depends upon the current of magnetic field.

c) State block diagram of 'Fuzzy logic' controller and explain function of each block.

4 M

Ans:

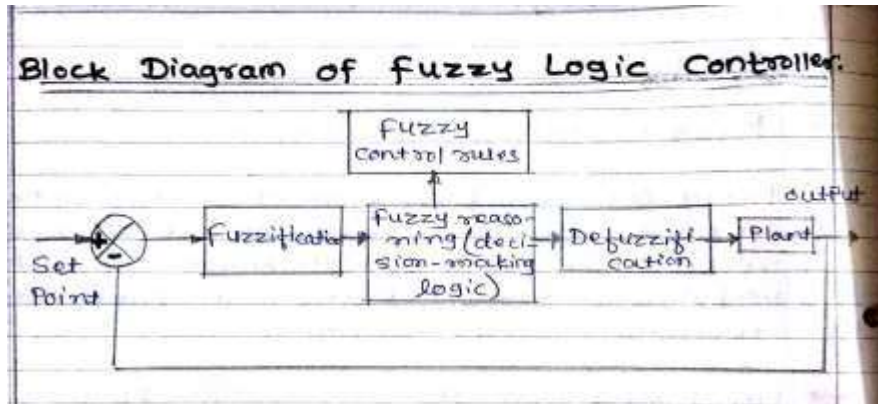

[Diagram- 2 Marks, Explanation -2 Marks)

OR

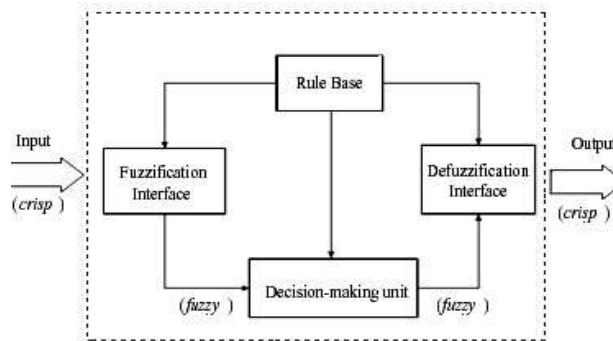

OR

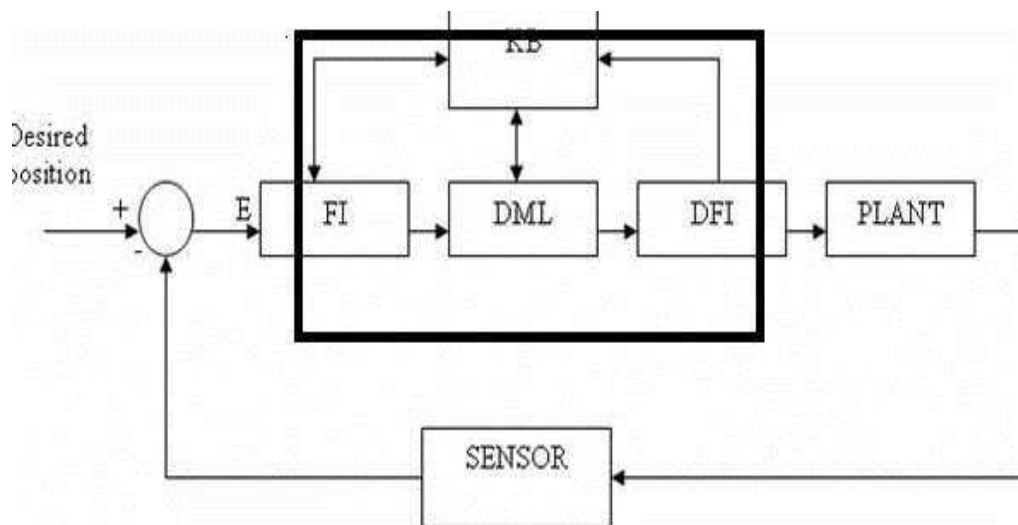

1 Fuzzification: It is the action of transforming a given state as crisp input into fuzzy values by evaluating membership function for purpose to be used by a fuzzy interference mechanism. Membership function forms a crucial part in fuzzy rule base model because actually they only define Fuzzification of control variable in other word

- Fuzzification is the process of making a crisp quantity fuzzy.

- In the real world, hardware such as a digital voltmeter generates crisp data, but these data are subject to experimental error.
- Fuzzification based on rule base or by decision making with knowledge base
- Membership function is bell shaped or triangular or trapezoidal shape

2. Fuzzy Inference:

Once membership function is found for each of variable an intelligent decision can be made to what output should be. This decision process is called interference this can be done knowledge base decision as well as rule base. This output then connected to Defuzzification block

3. Defuzzification:

Converts the fuzzy output of the inference engine to crisp using membership functions analogous to the ones used by the fuzzifier. A Defuzzification strategy is aimed at producing a non- fuzzy control action that best represent the possibility of an inferred fuzzy control action

d) Explain the principle of process control valves.

4 M

Ans:

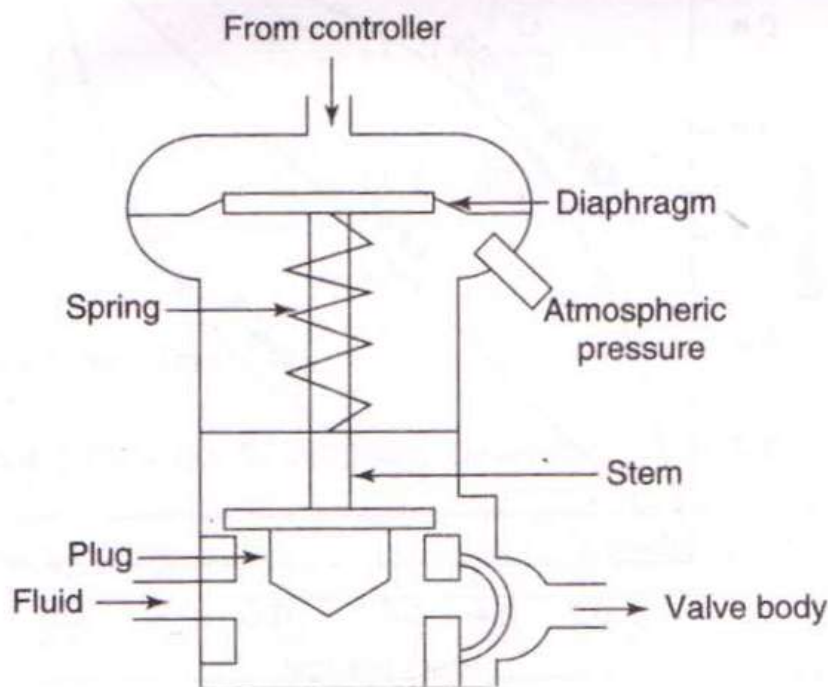

(Correct principle:2 Mark)

- A **control valve** is a **valve** used to **control fluid flow** by varying the size of the **flow** passage as directed by a signal from a controller. This enables the direct **control** of **flow** rate and the consequential **control** of **process** quantities such as pressure, temperature, and liquid level.
- The opening or closing of automatic control valves is usually done by electrical, hydraulic or pneumatic actuators. Normally with a modulating valve, which can be set to any position between fully open and fully closed, valve positioners are used to ensure the valve attains the desired degree of opening.
- Air-actuated valves are commonly used because of their simplicity, as they only

require a compressed air supply, whereas electrically-operated valves require additional cabling and switch gear, and hydraulically-actuated valves required high pressure supply and return lines for the hydraulic fluid.

e) Draw and explain the basic element of 'MEMS'.

4M

Ans:

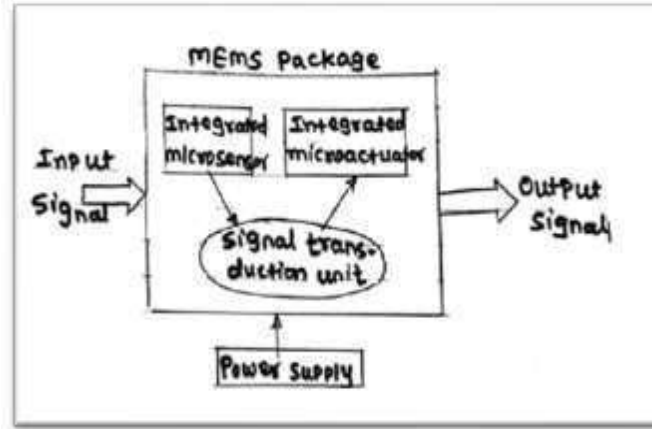

[Diagram- 2 Marks, Explanation -2 Marks)

1. Input signals: These are the signals admitted to the MEMS package from various sources or systems such as electrical, mechanical, chemical optical and so on.
2. MEMS package: It is a semiconductor chip which can be fabricated by suitable micromachining technique. It consists of micro sensor, micro actuators and a signal
3. Signal transduction unit: This unit is provided for conditioning the generated signals. The transduction processes includes amplification, filtration and signal conversion.
4. Output signals: These are the signals interfaced with the system to be controlled or monitored.
5. Due to monolithic integration of sensors, actuators and signal transduction unit, closed loop control system can be easily developed.

f) Explain with sketch, principle of working of 'Pick and place Robot'.

4M

Ans:

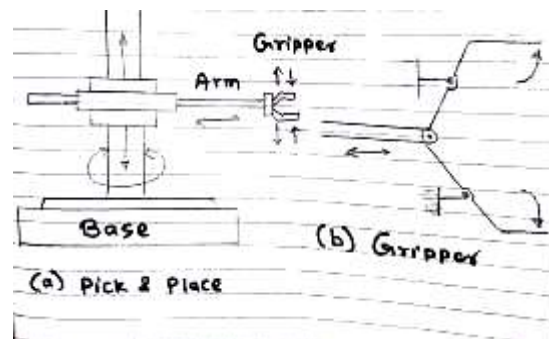

[Diagram- 2 Marks, Explanation -2 Marks)

Explanation:

The robot has three axes about which motion can occur.

- Rotation in a clockwise or anti-clock wise direction of the unit on its base
- Arm extension or contraction and arm up or down.
- Gripper can open or close.
- These movements can be actuated by the use of pneumatic cylinders operated by

solenoid controlled valves with limit switches to indicate when a motion is completed

- Thus clock wise rotation of the unit might result from the piston in a cylinder being extended and the anticlockwise direction by its retraction.
- Likewise the upward movement of the arm might result from the piston in a linear cylinder being extended and the downward motion from it retracting.
 - The extension of the arm by the piston in another cylinder extending and its return movement by the piston retracting.
 - The gripper can be opened or closed by the piston in a linear cylinder extending or retracting as.

Q. 4 Attempt any **TWO** of following: **16 M**

a) Explain with sketch, torque measurement using: (1) Stroboscope method (2) Capacitive method. **8 M**

Ans: (1) Stroboscope method **(Capacitive method :4 Mark Torque method:4 Mark)**

A torsion angle detection apparatus, wherein a pair of optical type of encoders are disposed on the coaxial center at a proper interval in the axial direction, and also, the measured shaft is inserted into the axial center position thereof and is secured to the rotary portion of each of the encoders, so that the torsion angle of the measured shaft may be detected with high accuracy and high speed response property from the difference in the detection position by each encoder by the use of an optical type of encoder of high resolution. high speed response property

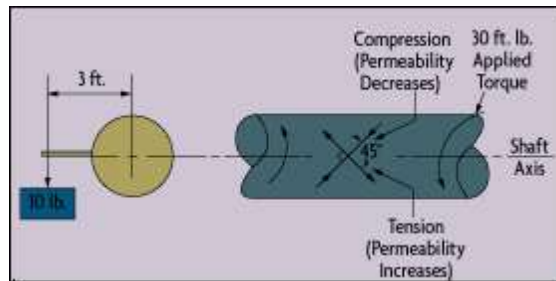

Torque = turning force*diameter of shaft (Unit- Nmm or KNmm)

$$T = F * 2 R$$

Where,

T=torque

F=Turning force

S= Radius of the shaft

Capacitive Method : The principles of capacitive measurement and ratio metric calculation provide the advantage of robustness towards environmental influences In order to measure the torsion angle resulting from the torque transmitted by a rotating shaft, we have modified the capacitive angle/angular speed sensor by mounting two asymmetric rotors on two concentric shafts between the sensor stators. Both grounded rotors realise a single effective rotor with a variable geometry, depending on the relative angle between the rotating shafts. These modifications extend the abilities of the sensor to measure the absolute angle (360°-range) and the angular velocity of the effective rotor with the ability to measure the difference-angle between the two rotors.

Figure 1 shows a typical mechanical construction for converting the torsion on a shaft into an angle between the two rotors. The torsion shaft carrying one rotor is mounted concentrically in a hollow and stiff shaft carrying the second rotor. From the measured torsion angle and the length and the G-modulus of the shaft the transmitted torque is calculated using Hooke's Law.

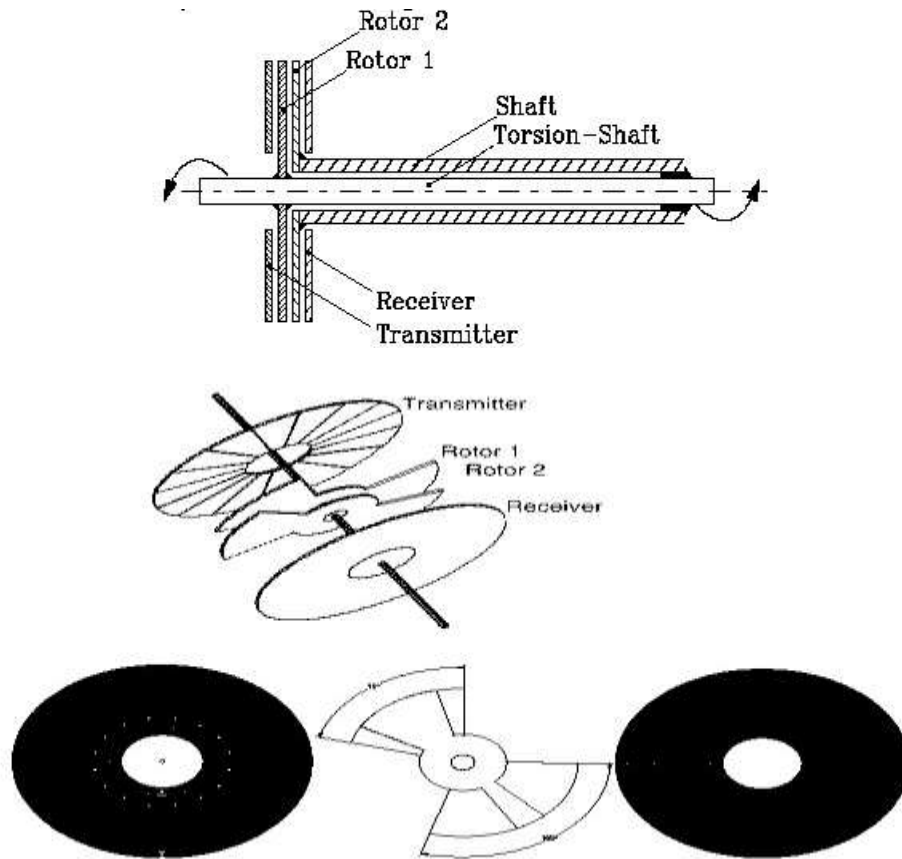

Figure 2 shows the electrode structure of the capacitive sensor. One stator plate is used as transmitter with 16 transmitting segments with centre angles of 22.5° , the other stator contains the receiving ring electrode. Two rotors with a symmetrically arranged blades with a centre angle of 60° (Figure 2) are mounted mirror-symmetrically on two concentric shafts as shown in Figure 1.

The shafts electrically connect the conductive rotors to ground potential. The zero position of the relative angle is defined for overlapping rotors building two blades with centre angles of 75° and 105° . From this asymmetrical geometry results the ability to determine the direction of the torsion or the sign of the torque, respectively, and the maximum range of the difference angle of $\pm 15^\circ$. As the applied torque changes the angle between the rotors, the electrical effective size of the rotor blades is changed. These changes influence the capacitive coupling between the transmitting segments and the receiving electrode.

In one measurement cycle a pulse sequence is applied to each segment. Depending on the rotor position and the effective size of the rotor the received signals change for each segment. By applying a ratiometric algorithm to the received signals, the signed relative angle between the rotors is calculated.

b) Explain with diagram how micro-controller is used for stepper motor control.

8 M

Ans:

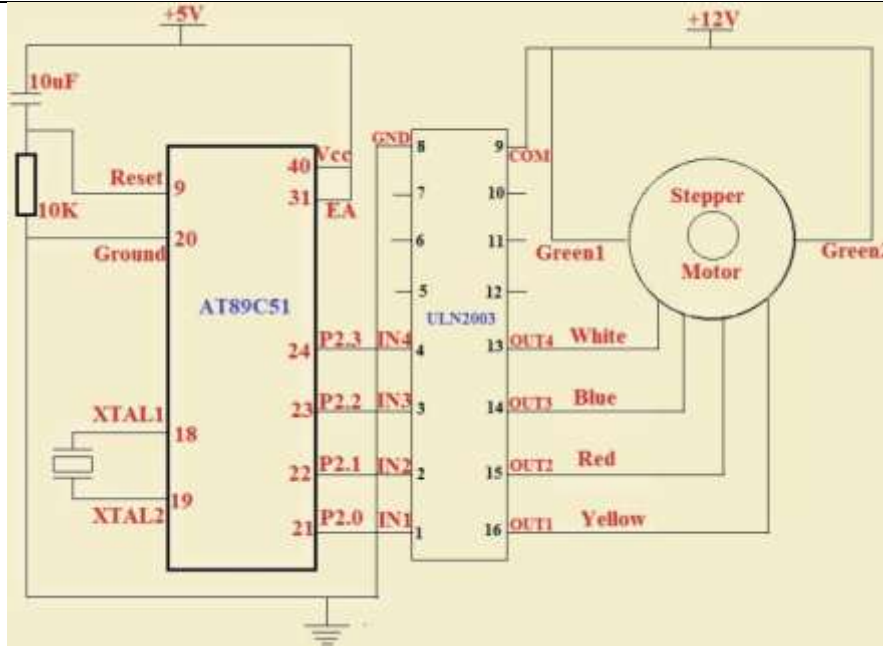

(Diagram:4
Mark,
Sequence
table-2
Mark,
Explanation
:2 Mark)

OR

STEP	YELLOW LEAD (End point1 of phase1)	BLUE LEAD (End point1 of phase1)	RED LEAD (End point1 of phase2)	WHITE LEAD (End point1 of phase2)
1	1	0	0	0
2	0	0	1	0
3	0	1	0	0
4	0	0	0	1

- A synchronous and brushless DC motor that converts electric pulses into mechanical movements and thus, rotates stepwise with a certain angle between each step for completing a full rotation is called as Stepper Motor. The angle between the steps of rotation of the stepper motor is termed as the stepper angle of the motor.
- The stepper motor controller is designed using 8051 microcontroller and switching circuit for controlling the speed of the stepper motor. The control switch circuit can be designed by using transistor switches or by using stepper motor controller IC such as ULN2003 in place of the transistors.
- The unipolar stepper motor can be rotated by energizing the stator coils in a sequence. The sequence of these voltage signals applied across the motor coils or leads is enough to drive the motor and hence, no driver circuit is required for controlling the direction of the current in the stator coils.
- By repeating the above sequence, the motor can be rotated in wave-drive- stepping mode either in a clockwise or anticlockwise direction based on the selection of end points. The table below shows the signal phase sequence for wave-drive-stepping

mode.

c) Describe with sketch, basic details of; (1) Poppet valve (2) Shuttle valve

8 M

Ans: A **poppet valve** (also called **mushroom valve**) is a valve typically used to control the timing and quantity of gas or vapors flow into an engine. It consists of a hole, usually round or oval, and a tapered plug, usually a disk shape on the end of a shaft also called a valve stem. The portion of the hole where the plug meets with it is referred to as the 'seat' or 'valve seat'. The shaft guides the plug portion by sliding through a valve guide. In **exhaust** applications, a pressure differential helps to seal the valve and in **intake** valves a pressure differential helps open it. Poppet valves date from at least the 1770s, when James Watt used them on his steam engines.

(Each valve: 4 Mark)

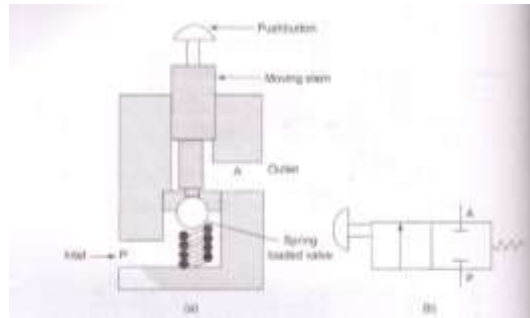

OR

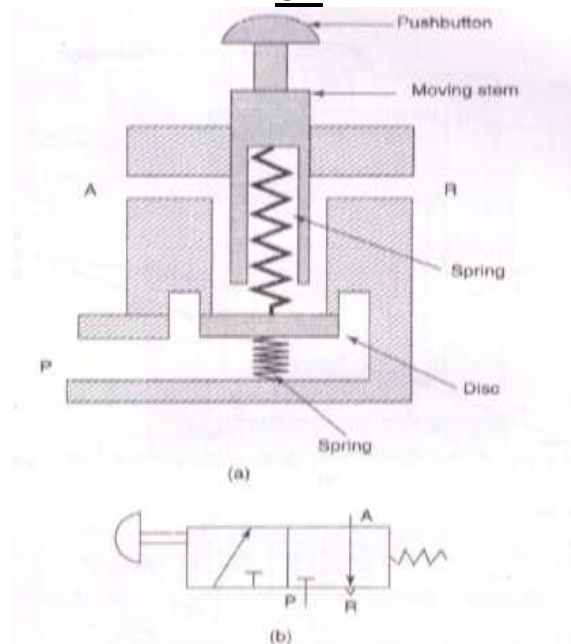

Poppet valves are used in many industrial processes, from controlling the flow of milk to isolating sterile air in the semiconductor industry. However, they are most well known for their use in internal combustion and steam engines, as described below.

A shuttle valve: is a type of valve which allows fluid to flow through it from one of two sources. Generally a shuttle valve is used in pneumatic systems, although sometimes it will be found in hydraulic systems.

Structure and function

The basic structure of a shuttle valve is like a tube with three openings; one on each end,

and one in the middle. A ball or other blocking valve element moves freely within the tube. When pressure from a fluid is exerted through an opening on one end it pushes the ball towards the opposite end. This prevents the fluid from traveling through that opening, but allows it to flow through the middle opening. In this way two different sources can provide pressure without the threat of back flow from one source to the other. In pneumatic logic a shuttle-valve works as an OR gate.

Symbol of shuttle valve

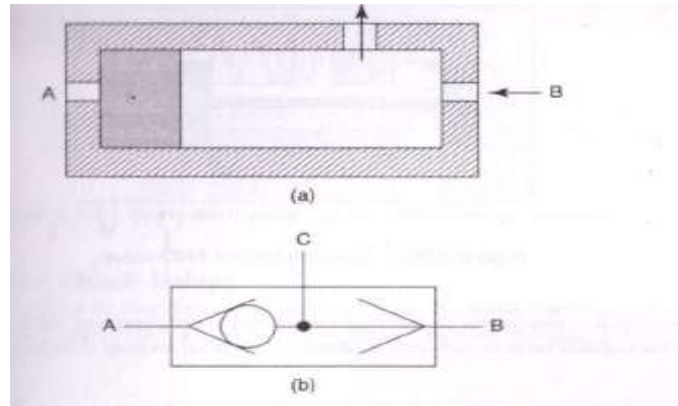

Q.5

Attempt any **FOUR** of following:

16 M

a) **State and explain working principle of Tacho generators.**

4M

Ans : **Principle:** An electromechanical generator is a device capable of producing electrical power from mechanical energy, usually the turning of a shaft.

1M

Diagram:

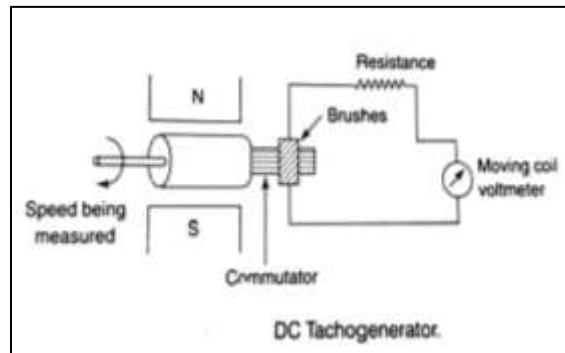

1M

Explanation: When not connected to a load resistance, generators will generate voltage roughly proportional to shaft speed. With precise construction and design, generators can be built to produce very precise voltages for certain ranges of shaft speeds, thus making them well-suited as measurement devices for shaft speed in mechanical equipment. A generator specially designed and constructed for this use is called tachogenerator.

2M

By measuring the voltage produced by a tachogenerator, you can easily determine the rotational speed of whatever its mechanically attached to. One of the more common voltage signal ranges used with tachogenerators is 0 to 10 volts. Tachogenerators can also indicate the direction of rotation by the polarity of the output voltage.

When a permanent-magnet style DC generator's rotational direction is reversed, the polarity of its output voltage will switch.
In measurement and control systems where directional indication is needed tachogenerators provide an easy way to determine that. Tachogenerators are frequently used to measure the speeds of electric motors, engines, and the equipment they power: conveyor belts, machine tools, mixers, fans, etc.

b) Give the significance of transducer and sensor with suitable example.

4M

Ans : Transducer and sensor used to measure other than electrical quantity with electrical system
Electrical transducer converts any physical quantity to measurable electrical quantity e.g. RTD which varies Electrical Property (Resistance) by change in temperature i.e. if temperature increase by certain value then Resistance of RTD will Change. This resistance can have converted into voltage and voltmeter can be calibrated in term of temperature with Celsius.

[NOTE :Significance with other example may consider for marks]

c) State the characteristics of PD and PID controllers with their control action equations.

4M

Ans: PID controller characteristics:

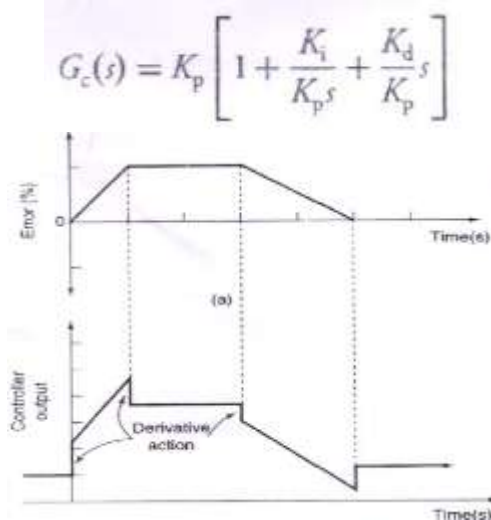

[Diagram- 2 Marks, Explanation - 2 Marks]

$$e_a(t) = e(t) + T_d \frac{de(t)}{dt} + K_i \int e(t) dt$$

In Laplace domain,

$$E_a(s) = E(s) + T_d s E(s) + \frac{K_i}{s} E(s) = (1 + s T_d + \frac{K_i}{s}) E(s)$$

PD controller

EQUATION

$$e_a(t) = e(t) + T_d \frac{de(t)}{dt}$$

In Laplace domain,

$$E_a(s) = E(s) + T_d sE(s)$$

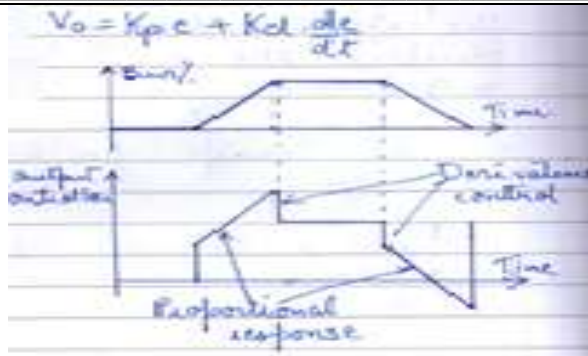

d) Draw a block diagram indicating the application of Fuzzy logic control in fully automatic washing machine.

4M

Ans:

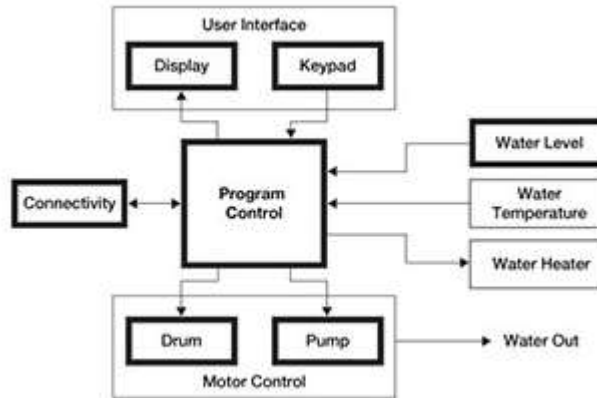

(NOTE : any other logical block diagram mark can be given)

e) Explain the concept of degree freedom of Robot with sketch.

4M

Ans: **DOF:** -Degree of freedom is a term used to describe a robot's freedom of motion in 3 dimensional spaces specifically the ability to move forward and backward, up and down, left and right. For each DOF a joint is required.

(Concept:2 Marks, Significance :2 Marks)

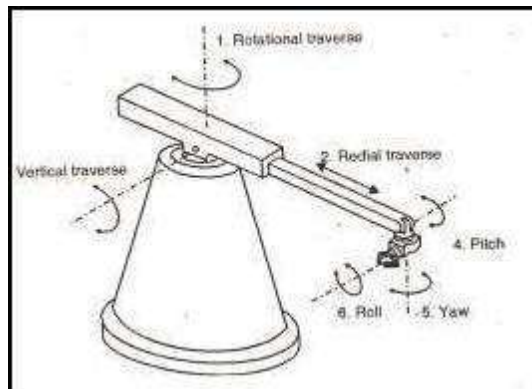

Significance Of Degree Of Freedom In Robot :

Degrees of freedom defined modes in which a mechanical device or system can move.



	<p>The number of degrees of freedom is equal to the total number of independent displacements or aspects of motion. A machine may operate in two or three dimensions but have more than three degrees of freedom. The term is widely used to define the motion capabilities of robots. Consider a robot arm built to work like a human arm. Shoulder motion can take place as pitch (up and down) or yaw (left and right). Elbow motion can occur only as pitch. Wrist motion can occur as pitch or yaw. Rotation (roll) may also be possible for wrist and shoulder. Such a robot arm has five to seven degrees of freedom. If a complex robot has two arms, the total number of degrees of freedom is doubled. In an android, additional degrees of freedom exist in the end effectors, the legs and the head. Fully functional androids and multi-legged mobile robots can have more than 20 degrees of freedom. An example is Project Nao, an intelligent android designed for the consumer market. Nao, which looks superficially like a large space-age doll, has 25 degrees of freedom</p>	
f)	Enlist and explain the various component of Mechatronic system.	4M
Ans:	<p>Various of Mechatronics systems can be classified under following categories:</p> <p>Information systems Mechanical systems Electrical systems Computer systems Sensor and actuators Real-time interfacing</p> <p>Mechanical systems: Actuators: Actuations is the result of direct physical action on process directly. In any physical process, there is motion or some sort of action. This motion or action can be applied to mechanical processes or structure through actuators. E.g. Stepper motor, Solenoids, DC motor, synchros etc. Sensors: It accepts the physical quantities (process variables) from mechanical processes (Dynamic system) and converts them into a signal that can be processed by the system. Electrical Systems: Input signal conditioning and interfacing: The output of a transducer may be too small, too noisy, contain DC offset, not be compatible with next stages, and contain wrong information. Signal conditioning process if amplification using amplifier in which the signal magnitude is increased. Digital control architectures: PLCs are industrial devices used for interfacing and controlling analog and digital devices. Microcontrollers are low cost, versatile, small size and easy programming device. Graphical Displays: Various types of graphical displays are used for displaying measured variable, outputs, voltages etc. waveforms can be displayed for various analyses by CRT. Controllers: It takes input from output signal conditioning and interface and it is not equal to the required set points then it is adjusted based on generated error and again signal is given to actuators and sensors.</p>	List:2M & Explanation 2M
Q.6	Attempt any TWO of following:	16 M
a)	Describe the principle of operation of; (1) Linear actuators (2) DC motors	8M
Ans:	<p>Principle of linear actuator:</p> <p>A linear actuator is an actuator that creates motion in a straight line, in contrast to</p>	(Each:4 Marks)

the circular motion of a conventional electric motor. Linear actuators are used in machine tools and industrial machinery, in computer peripherals such as disk drives and printers, in valves and dampers, and in many other places where linear motion is required. Hydraulic or pneumatic cylinders inherently produce linear motion. Many other mechanisms are used to generate linear motion from a rotating motor. There are two types of linear actuators

- i) Single acting cylinder
- ii) Double acting cylinder

Following shows construction of double acting cylinder

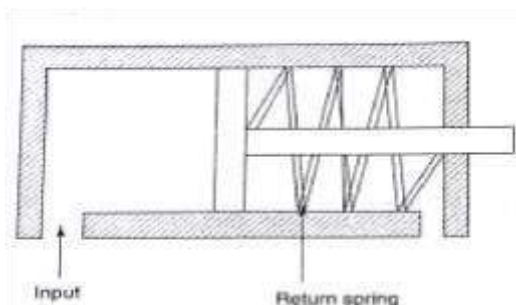

DC motor

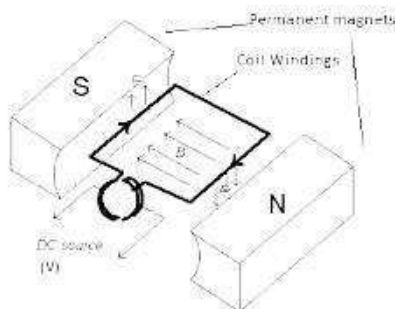

OR

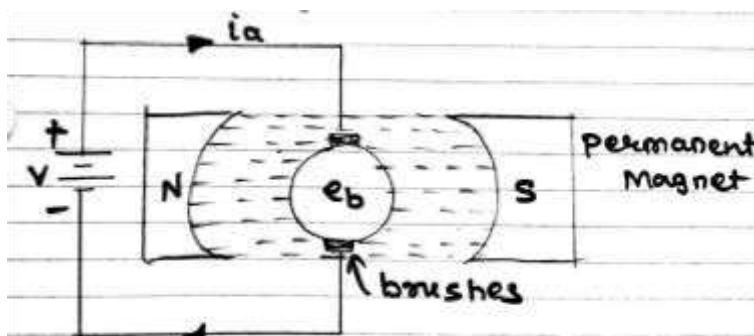

It is based on the principle that when a current-carrying conductor is placed in a magnetic field, it experiences a mechanical force whose direction is given by Fleming's Left-hand rule and whose magnitude is given by

Force, $F = B I l$ newton Where, B is the magnetic field in weber/m².

I is the current in amperes and

l is the length of the coil in meter.

- The force, current and the magnetic field are all in different directions. If an Electric current flows through two copper wires that are between the poles of a magnet, an upward force will move one wire up and a downward force will move the other wire down.
- The loop can be made to spin by fixing a half circle of copper which is known as commutator, to each end of the loop.
- Current is passed into and out of the loop by brushes that press onto the strips. The brushes do not go round so the wire does not get twisted. This arrangement also makes sure that the current always passes down on the right and back on the left so that the rotation continues. This is how a simple DC Electric motor works.

b) Explain the constructional features of MEMS accelerometer used in airbag sensors for car safety.

8M

Ans:

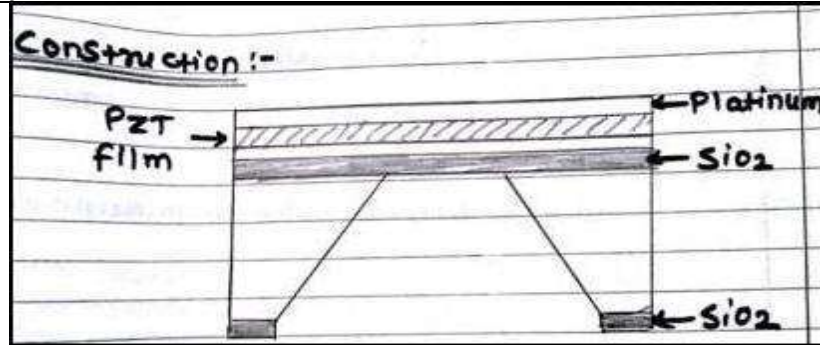

OR

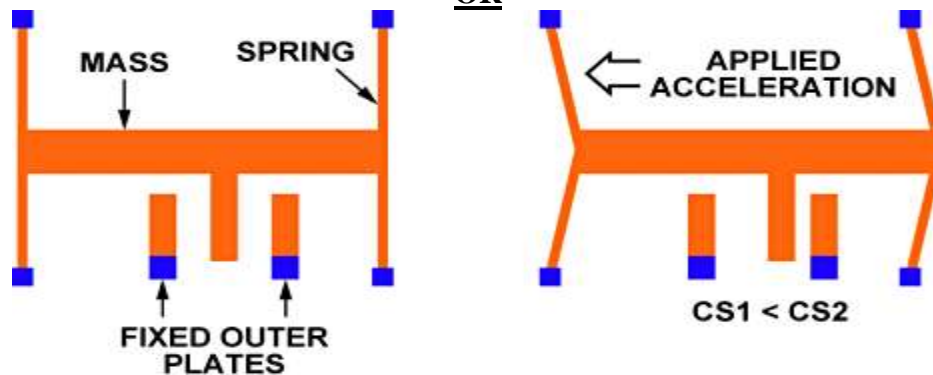

(Explanation: 4 Marks, Diagram: 4 Marks)

Explanation- Mechanical ignition airbags fit inside the steering wheel pad. When a collision occurs, the inertial sensor moves, setting off a mechanical igniter and inflator to deploy the airbag. As the sensor and igniter were in the same unit, the compact airbag unit easily fit most steering wheels, allowing broad application of the airbag unit. With electrical ignition airbags, a computer monitors signals from the impact sensor. When it detects a collision, the computer sets off the airbag's igniter electrically. Therefore, the sensor need not be close to the airbag, but can be placed anywhere on the vehicle and connected to the airbag with wiring. This is especially effective when fitting both driver- and passenger-side airbags

c) Explain with block diagram, working of micro-controller based anti-lock braking system.

8M

Ans: An ABS is a system on motor vehicles which prevents the wheels from locking while braking stopping safely is one of the most important functions a motor vehicle can perform.

(Explanation: 4 Marks, Diagram: 4 Marks)

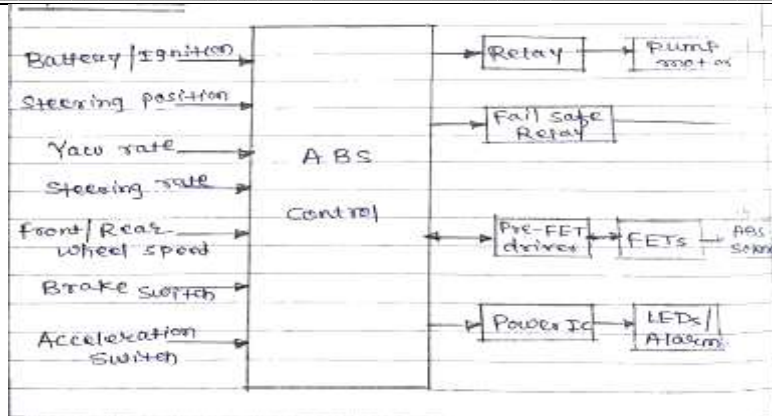

Explanation:

Failure of the brake system will almost invariably results in property damage, personal injury or even death.

An ABS allow the driver to maintain steering control under heavy braking by preventing a skid and allowing the wheel to continue to roll forward and create lateral control, as directed by driver steering inputs.

A typical ABS is composed of a central electronic unit, four speed sensors (one for each wheel) and two or more hydraulic valves on the brake circuit.

The electronic unit constantly monitors the rotation speed of each wheel. The pulsed output from the wheel speed sensors goes to an electronic controller which monitors each wheels speed relative to the speed of the other wheels.

As long as the brakes are not being applied and all of the monitored wheels are rotating at roughly the same speed, the system takes no action.

If however the brakes are being applied and one or more monitored wheels suddenly beings to reduce speed indicating a loss of traction with load the controller then activates the antilock system.

When it senses that any one of the wheels is rotating slower than the others, it moves the valves to decrease the pressure on the braking circuit, effectively reducing the braking force on that wheel.